

Optically Coupled Isolator

OPI120, OPI123



Features:

- 15 kV electrical isolation
- Choice of phototransistor or photodarlington output
- Hermetically sealed LED and photosensor
- Base contact for conventional transistor biasing (OP120 only)
- UL recognized File No. E58730*

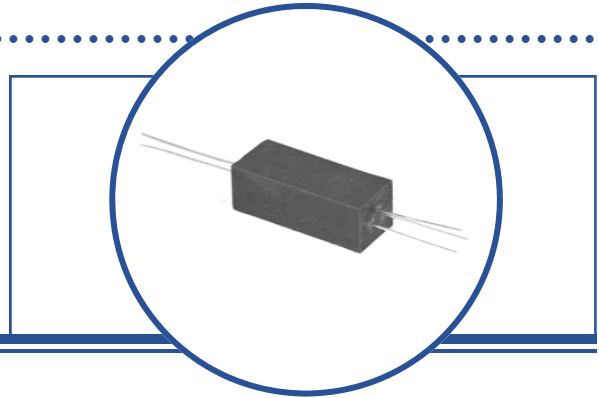

Description:

Each Optoisolator in this data sheet contains an infrared Light Emitting Diode (LED) and a NPN silicon Photosensor. The **OPI120** has an 890 nm Light Emitting Diode (LED) and NPN phototransistor sensor, whereas the **OP123** has a 890 nm LED and a photodarlington sensor. The devices are sealed in a precast opaque housing with a optically transmissive path between the LED and the photosensor.

The Optoisolators in this data sheet are UL approved under E 58730.

This series is designed for transmission of information between one power supply voltage another where the potentials during surge conditions are not greater than the guaranteed isolation voltage.

Custom electrical, wire and cabling and connectors are available. Contact your local representative or OPTEK for more information.

TX and TXV processing is available. For more information, contact your local representative or OPTEK.

Applications:

- High voltage isolation between input and output
- Electrical isolation in dirty environments
- Industrial equipment
- Medical equipment
- Office equipment

Ordering Information							
Part Number	LED Peak Wavelength	Sensor	Isolation Voltage (,000)	CTR Min	I _F (mA) Typ / Max	V _{CE} (Volts) Max	Lead Length / Spacing
OPI120	890 nm	Transistor	15	20	10 / 50	25	0.40" / 0.75"
OPI123	or 935 nm	Darlington		50		20	



RoHS

OPTEK reserves the right to make changes at any time in order to improve design and to supply the best product possible.

Absolute Maximum Ratings ($T_A = 25^\circ\text{C}$ unless otherwise noted)

Storage Temperature	-55° C to +100° C
Operating Temperature	-55° C to +100° C
Input-to-Output Isolation Voltage ⁽¹⁾⁽²⁾	± 15 kVDC
Lead Soldering Temperature (1/16" (1.6 mm) from case for 5 seconds with soldering iron) ⁽³⁾	260° C

Input Diode

Forward DC Current ⁽⁴⁾	150 mA
Reverse DC Voltage	3 V
Power Dissipation ⁽⁵⁾	200 mW

Output Photosensor

Collector-Emitter Voltage	
OPI120	25 V
OPI123	20 V
Emitter-Collector Voltage	5 V
Collector-Base Voltage	
OPI120	25 V
Power Dissipation ⁽⁶⁾	250 mW

Notes:

- (1) Measured with input and output leads shorted in air with a maximum relative humidity of 50%. If suitably encapsulated or oil-immersed, the isolation voltage is increased to 25 kV minimum.
- (2) UL recognition is for 3750 VAC to 100° C.
- (3) RMA flux is recommended. The duration can be extended to 10 seconds maximum when flow soldering.
- (4) Derate linearly 2.0 mA/°C above 25°C.
- (5) Derate linearly 2.67 mA/°C above 25°C.
- (6) Derate linearly 3.33 mA/°C above 25°C.

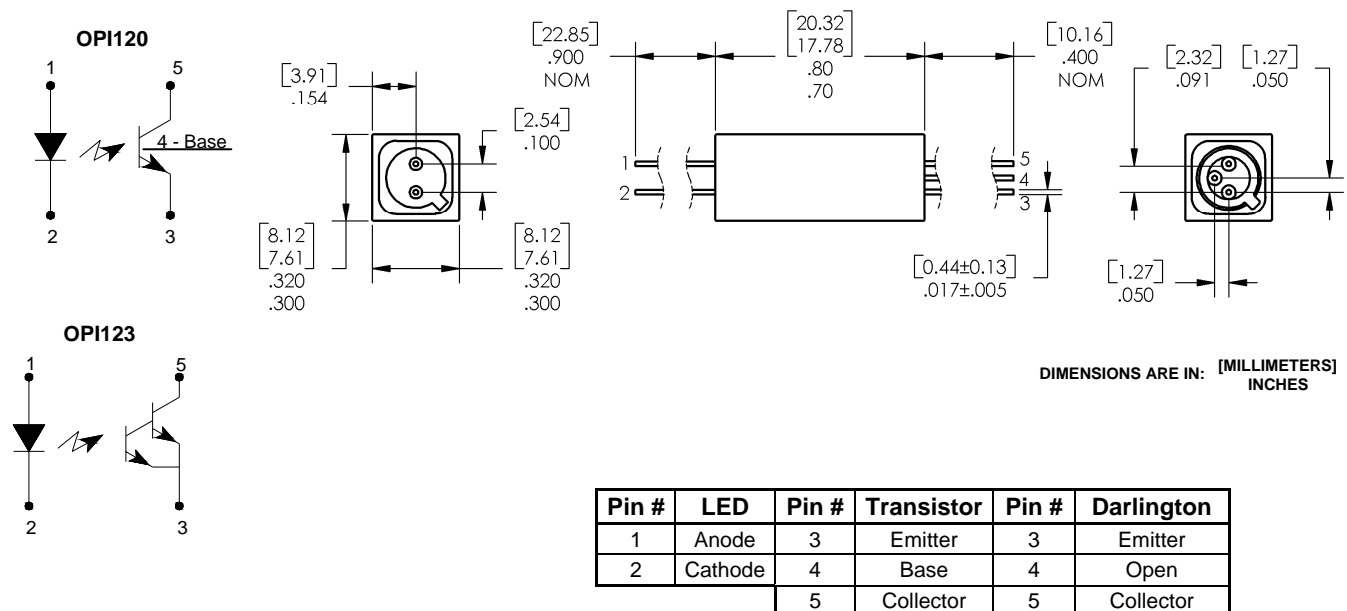

OPTEK reserves the right to make changes at any time in order to improve design and to supply the best product possible.

Electrical Characteristics (-40°C to +85°C unless otherwise noted)

SYMBOL	PARAMETER	MIN	TYP	MAX	UNITS	TEST CONDITIONS
--------	-----------	-----	-----	-----	-------	-----------------

Input Diode

V_F	Forward Voltage OPI120 OPI123	- -	- -	1.5 1.5	V	$I_F = 30 \text{ mA}$ $I_F = 10 \text{ mA}$
I_R	Reverse Current	-	-	100	μA	$V_R = 3 \text{ V}$

Output Photosensor (See OP236 for additional information - for reference only)

$V_{(BR)CEO}$	Collector-Emitter Breakdown Voltage OPI120 OPI123	25 20	- -	- -	V	$I_C = 1 \text{ mA}$ $I_C = 1 \text{ mA}$
$V_{(BR)ECO}$	Emitter-Collector Breakdown Voltage	5	-	-	V	$I_E = 100 \mu\text{A}$
$V_{(BR)CBO}$	Collector-Base Breakdown Voltage OPI120	25	-	-	V	$I_C = 1 \text{ mA}$
I_{CEO}	Collector-Emitter Dark Current	-	-	100	nA	$V_{CE} = 10 \text{ V}$

Coupled (See OP804 and OP805 for additional information - for reference only)

I_C/I_F	DC Current Transfer Ratio OPI120 OPI123	20 50	70 -	- -	%	$I_F = 10 \text{ mA}, V_{CE} = 5 \text{ V}$ $I_F = 10 \text{ mA}, V_{CE} = 2 \text{ V}$
$V_{CE(SAT)}$	Collector Saturation Voltage OPI120 OPI123	- -	- -	0.5 1.2	V	$I_F = 30 \text{ mA}, I_C = 1 \text{ mA}$ $I_F = 5 \text{ mA}, I_C = 1 \text{ mA}$
V_{ISO}	Isolation Voltage ⁽¹⁾	15	-	-	kV	See note 1
t_r, t_f	Output Rise Time, Output Fall Time OPI120 OPI123	- -	2 40	- -	μs	See Test Circuit

Notes:

- (1) Measured with input and output leads shorted in air with a maximum relative humidity of 50%.
If suitably encapsulated or oil-immersed, the isolation voltage is increased to 25 kV minimum.

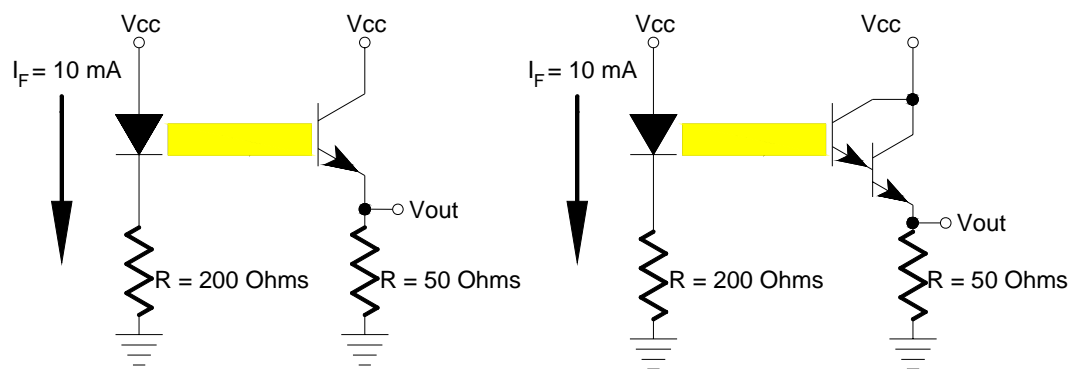

Test Circuit

OPTEK reserves the right to make changes at any time in order to improve design and to supply the best product possible.